

# **H2O-APEX ULTRA LIQUID COOLING KIT**

## **TUTORIAL & INSTALLATION GUIDE**

# Water cooling Swiftech

*manufacturer of the world's best active coolers*

These instructions are updated on a regular basis. Please visit our web site at  
<http://www.swiftech.com>

## Packing List

QTY	ITEM
1	APOGEE GT water-block, including hold-down plates (multi sockets + AM2), various processors mounting systems, and (2) hose clamps
1	MCP655-B pump, including mounting hardware and (2) ½" hose clamps
1	MCRES-Micro, including mounting hardware, ½" hose-barb fittings, and (2) hose clamps, + mounting hardware for bracketry installation: 1 "L" bracket, 2 "U" brackets, Philips screws, 3 teeth washers, 5 zinc plate washers.
1	MCR220 Radiator assembly, including (2) pre-installed 120mm fans with fan guards, mounting hardware, ½" black nylon hose barb fittings, (2) 12v to 7v adapters, (2) 12v to 5v 3-pin to 4-pin Molex adapters, and (2) hose clamps And Pre-installed MCB-120 Radbox, with mounting hardware
8	Feet 7/16" industrial grade PVC tubing
1	Length (40") Smartcoils 625 clear
1	2 Oz. Bottle of HydrX concentrated coolant
1	Syringe of Arctic Céramique thermal compound

## TABLE OF CONTENTS

<b>I.</b>	<b>PLANNING .....</b>	<b>4</b>
1.	<b>General Guidelines.....</b>	<b>4</b>
2.	<b>Tube Routing .....</b>	<b>4</b>
<b>II.</b>	<b>INSTALLATION OF THE COOLING COMPONENTS .....</b>	<b>5</b>
1.	<b>MCR220 Radiator installation .....</b>	<b>6</b>
	<input type="checkbox"/> Installation .....	6
2.	<b>APOGEE GT Water-block installation.....</b>	<b>9</b>
	<input type="checkbox"/> Intel® Pentium® 4 and Pentium® D Socket LGA 775 .....	11
	<input type="checkbox"/> Intel® Xeon™ Socket 604 “Nocona” 800 MHz FSB motherboards.....	12
	<input type="checkbox"/> AMD® 64, Sempron®, Opteron® Socket 754, 939, 940.....	13
	<input type="checkbox"/> AMD® 64, FX, X2, Sempron®, socket AM2.....	14
3.	<b>Re-installing the motherboard .....</b>	<b>16</b>
4.	<b>Pump installation .....</b>	<b>16</b>
	<input type="checkbox"/> General Use.....	16
	<input type="checkbox"/> Physical installation.....	16
	<input type="checkbox"/> Pump operating precautions:.....	16
5.	<b>Preparing the tubing .....</b>	<b>18</b>
6.	<b>MCRES-Micro reservoir Installation .....</b>	<b>19</b>
	<input type="checkbox"/> Installation .....	19
	<input type="checkbox"/> Preparing the coolant .....	20
	<input type="checkbox"/> Re-installing your power-supply.....	21
	<input type="checkbox"/> Filling-up the circuit .....	22
7.	<b>Troubleshooting .....</b>	<b>23</b>
8.	<b>Draining the system .....</b>	<b>23</b>
9.	<b>Periodic Maintenance.....</b>	<b>23</b>
10.	<b>Optional Components .....</b>	<b>23</b>

## INTRODUCTION

*Congratulations on your purchase of a Swiftech™ H2O-APEX liquid cooling system!*

*This kit has been designed to facilitate the installation of the components with a minimum of case modifications. While all attempts have been made to make the installation of this system user friendly, please note that this system is intended for users that are well versed in installing computer components.*

### DISCLAIMER

While all efforts have been made to provide the most comprehensive tutorial possible, Swiftech assumes no liability expressed or implied for any damage(s) occurring to your components as a result of using Swiftech cooling products, either due to mistake or omission on our part in the above instructions, or due to failure or defect in the Swiftech™ cooling products.

In addition, Swiftech assumes no liability, expressed or implied, for the use of this product, and more specifically for any, and all damages caused by the use of this product to any other device in a personal computer, whether due to product failure, leak, electrical short, and or electro-magnetic emissions.

### WARRANTY

Our products are guaranteed for 12 months from the date of delivery to the final user against defects in materials or workmanship. During this period, they will be repaired or have parts replaced provided that: (I) the product is returned to the agent from which it was purchased; (II) the product has been purchased by the end user and not used for hire purposes; (III) the product has not been misused, handled carelessly, or other than in accordance with any instructions provided with respect to its use. This guarantee does not confer rights other than those expressly set out above and does not cover any claims for consequential loss or damage. This guarantee is offered as an extra benefit and does not affect your statutory rights as a consumer.

## I. Planning

### 1. GENERAL GUIDELINES

- Please read this guide carefully and entirely before you start this installation. Plan your installation ahead. Observe the relative position of the components for possible interference with other components.
- Never work with electricity connected to the computer while work is in progress.
- Because some work is necessary that will require cutting holes in the case, it is strongly recommended to remove all the components from the case prior to begin with this installation.
- After the metal work has been completed, carefully clean the case to remove all metal debris.
- Once the time has come to re-install the motherboard and complete the liquid-cooling circuit, the motherboard should be disconnected from the power-supply at all times during the entire mock-up phase of the installation. In case of a spill or leak on the motherboard, do not panic! As long as the motherboard is not electrically connected, no harm is done. You must however thoroughly dry the exposed area, using a hair dryer for example, and wait a minimum of 6 to 8 hours prior to re-connecting the motherboard to its power source.
- The reservoir should preferably be installed at the highest point of the cooling circuit (top 5 ¼" tray), although this is not absolutely necessary if all the other components are self-purging.
- Think about the airflow inside your chassis. In liquid-cooling environments, it is always better to draw fresh air from the outside through the radiator, as opposed to using the warm air from inside the computer.
- Make sure to dry-fit all components before making final connections and filling the water-cooling system.

### 2. TUBE ROUTING

- The tubing for the water-cooling system must be routed to form a complete loop that includes all elements of the system. When daisy-chaining components, the simplest and most natural route is usually the best. Always avoid sharp bends that would kink the tubing!
- The following table contains examples on how to establish connections between the different elements of a cooling circuit based on multiple possible configurations. These are guidelines only, and may change depending on the relative position of the components

inside your chassis.

- ❑ From a performance standpoint there is very little performance to be gained from strictly controlling the component sequence: the maximum delta T (difference in temperature) between any two points of the liquid cooling circuit does not exceed 1°C. Whenever possible, performance oriented users will typically want to route the radiator discharge(s) tube(s) to the inlet of the CPU cooler, since the fluid exiting the radiators is always the coolest.

**Devices:**        **(1) CPU cooler + (1) Radiator + Pump-reservoir assembly**

- Connect:
- Pump discharge to radiator inlet
  - Radiator discharge to CPU cooler inlet
  - CPU cooler discharge to reservoir inlet
  - Reservoir discharge to pump inlet – MANDATORY!

Alternatively,

- Connect:
- Pump discharge to CPU cooler inlet
  - CPU cooler discharge to radiator inlet
  - Radiator discharge to reservoir inlet
  - Reservoir discharge to pump inlet – MANDATORY!

**Devices:**        **(1) CPU cooler + (1) VGA cooler + (1) Radiator + Pump-reservoir assembly**

- Connect:
- Pump discharge to VGA Cooler inlet
  - VGA cooler discharge to radiator inlet
  - Radiator discharge to CPU cooler inlet
  - CPU cooler discharge to reservoir inlet
  - Reservoir discharge to pump inlet – MANDATORY!

Alternatively,

- Connect:
- Pump discharge to CPU cooler inlet
  - CPU cooler discharge to VGA cooler inlet
  - VGA cooler discharge to radiator inlet
  - Radiator discharge to reservoir inlet
  - Reservoir discharge to pump inlet – MANDATORY!

**Devices:**        **(1) CPU cooler + (1) VGA Cooler + (1) chipset Cooler + (1) Radiator + Pump-reservoir assembly**

- Connect:
- Pump discharge to chipset cooler inlet
  - Chipset cooler discharge to VGA cooler inlet
  - VGA cooler discharge to radiator inlet
  - Radiator discharge to CPU cooler inlet
  - CPU cooler discharge to reservoir inlet
  - Reservoir discharge to pump inlet – MANDATORY!

Alternatively,

- Connect:
- Pump discharge to CPU cooler inlet
  - CPU cooler discharge to chipset cooler inlet
  - Chipset cooler discharge to VGA cooler inlet
  - VGA cooler discharge to radiator inlet
  - Radiator discharge to reservoir inlet
  - Reservoir discharge to pump inlet – MANDATORY!

**Devices:**        **Dual CPU cooler and VGA cooler (SLI) configurations**

- Connect:
- CPU coolers in series: CPU cooler (1) discharge to CPU cooler (2) inlet
  - VGA coolers in series: VGA cooler (1) discharge to VGA cooler (2) inlet

**Devices:**        **Dual Radiators: A second radiator can be added anywhere in the loop in series with the other components, for example**

- Connect:
- Pump discharge to radiator (1) inlet
  - Radiator (1) discharge to VGA cooler inlet
  - VGA Cooler discharge to chipset cooler inlet
  - Chipset cooler discharge to radiator (2) inlet
  - Radiator (2) discharge to CPU cooler inlet
  - CPU cooler discharge to reservoir inlet
  - Reservoir discharge to pump inlet – MANDATORY!

## II. Installation of the cooling components

**Warning!** Placement of the cooling components may vary depending on your chassis and motherboard configurations. A mock-up installation is thus necessary to estimate the length of the different sections of tubing that will be required between each component.

The following is the recommended sequence of components installation.

1. Radiator and fan
2. Water-block(s)
3. Pump
4. Reservoir

## 1. MCR220 RADIATOR INSTALLATION

### Preamble:

The MCR220™ dual 120mm radiator ships with the fans and the Radbox chassis already pre-assembled to the radiator. It is assumed in effect that users will take advantage of our Radbox concept (external radiator installation) due to the benefits it provides and ease of installation. In such context, the following installation guide describes this type of installation. We also recognize that due to various considerations (cosmetics, space, or simply user preference) a number of users will wish to install the MR220 radiator internally. Because of the large size of the radiator, it is most likely that an internal installation will require extensive modifications in most computer cases. Because these modifications depend on the structure and dimensions of each individual chassis, we simply cannot provide precise installation instructions to this effect. Here are some general guidelines that advanced "case-modders" should take into consideration:

### Radiator installation, general considerations:

For optimum performance radiators require an unobstructed source of cool air. This dictates either an external mounting or one on/in the case where the radiator will draw cool air from the exterior. The second consideration is the placement of the inlet and outlet connections; at least one connection should be at the 'top' of the radiator to make it self-purging.

An external mounting can be effectuated by means of the RadBox affixed to the backside of the case and the tubing routed through holes drilled in the case underneath the power-supply. This places the connections at the top of the radiator and it will preclude the accumulation of air in the radiator.

Single 120mm fan radiators can be mounted over appropriately sized openings in a variety of cases; conversely, mounting a dual 120mm radiator is considerably more difficult and generally results in placing the radiator 'inverted' at the top, or 'right side up' at the bottom. Note that the 'inverted' mounting places the inlet and outlet facing down; this mounting will accumulate air over time. Placing the radiator 'right side up' in the case bottom will make the radiator self-purging, but it will gather dust VERY quickly if adjacent to the floor. In any case, mounting a dual 120mm radiator inside a case will require some extensive case modifications for the air inlet.

### □ Installation

- Place the radiator assembly on the back of the computer to roughly estimate where it will fit best.
- You need to consider the following clearance issues:
  - Exit cables and connectors from various PCI devices: the Radbox base plate can be moved in both vertical and horizontal directions to allow clearance for the cables
  - Opening the side panel once the Radbox is installed: the Radbox is supplied with various nylon spacers to separate the base plate from the surface of the back-panel and to provide clearance for opening of the side-panel.
  - Note that a chassis with 80mm fan opening(s) is likely to provide a very good range of adjustments. Conversely, a chassis featuring a single 120mm fan opening the base-plate is a direct bolt on, but offers no adjustments, which may or may not suit our installation for the purpose of positioning the radiator. In that case, it will become necessary to drill (4) mounting holes of 0.150" (~3.5mm) in diameter to install the base plate at the desired location.
- Securing the base plate at the desired location.

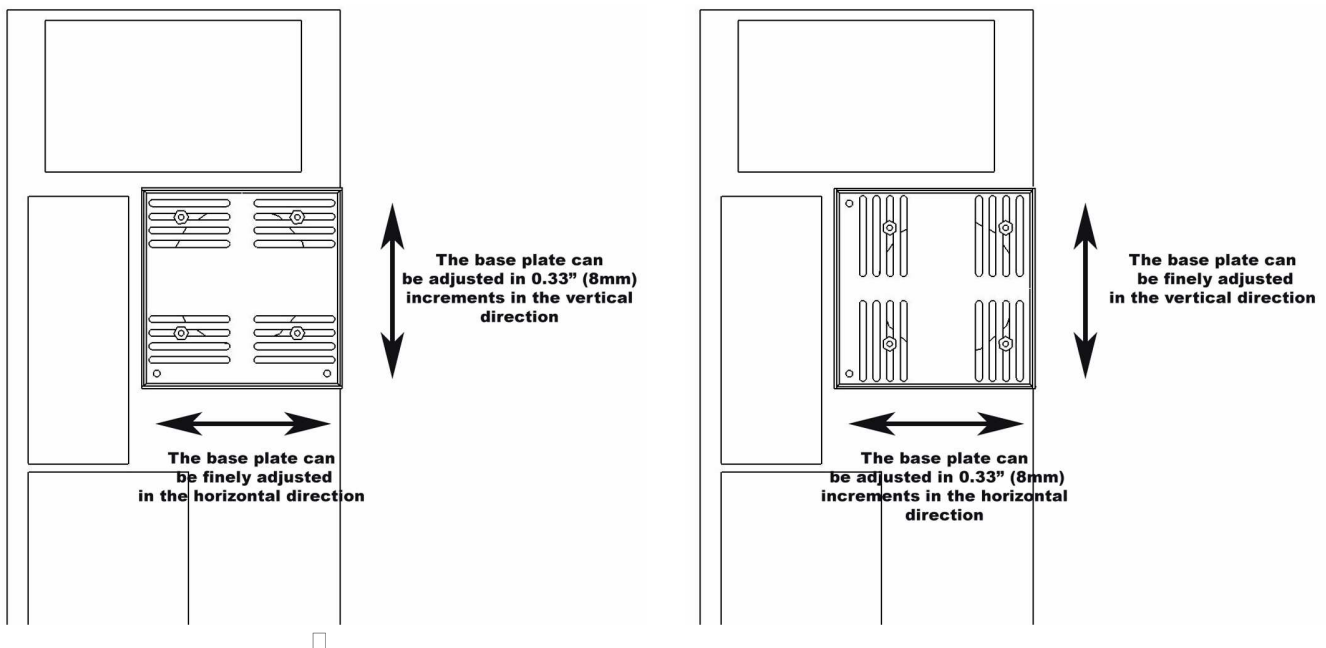

- Once satisfied with the position, bolt down the Radbox back-plate with the provided nylon nuts.
- Next, you will need to mark the location of the holes that must be drilled to allow routing of the tubes through the computer back-panel. You can cut two small pieces of the provided PVC tubing and install these to the radiator hose barbs, then temporarily mount the radiator assembly onto the back-plate. The tubing will provide a convenient way to mark the position of the holes as shown below:



- Remove the radiator assembly from the back-plate and mark the center of the circle.
- Two rubber grommets are provided with your kit so that you can route the tube through the case without damaging the tubing with the sharp edges of the hole. The required hole diameter for the grommet is 7/8" (23mm).
- To cut the holes, use a heavy-duty Bimetal hole saw of 7/8" in diameter:

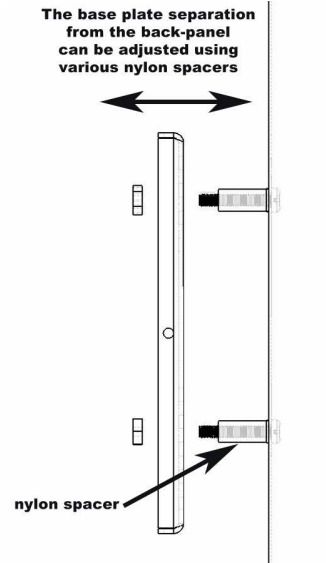

- Once the two holes are cut, de-burr the edges, and install the grommets.
- Install your radiator assembly onto the back plate.

Once the tubes are connected to the radiator, the final results will look like so:



- Finally, you need to route the fan wires through the back-panel. This can be done easily with the provided PCI adapter plate featuring a hole and grommet for protection of the wire.

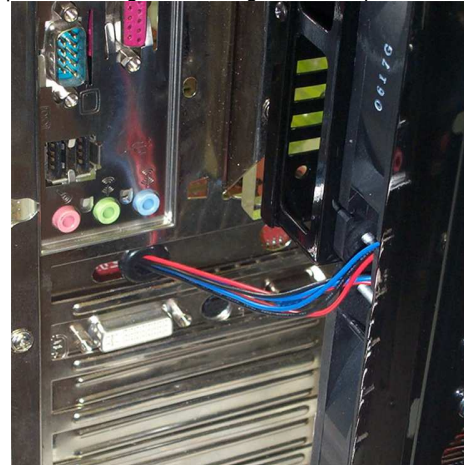

**Your MCR220 Radiator is now installed!**

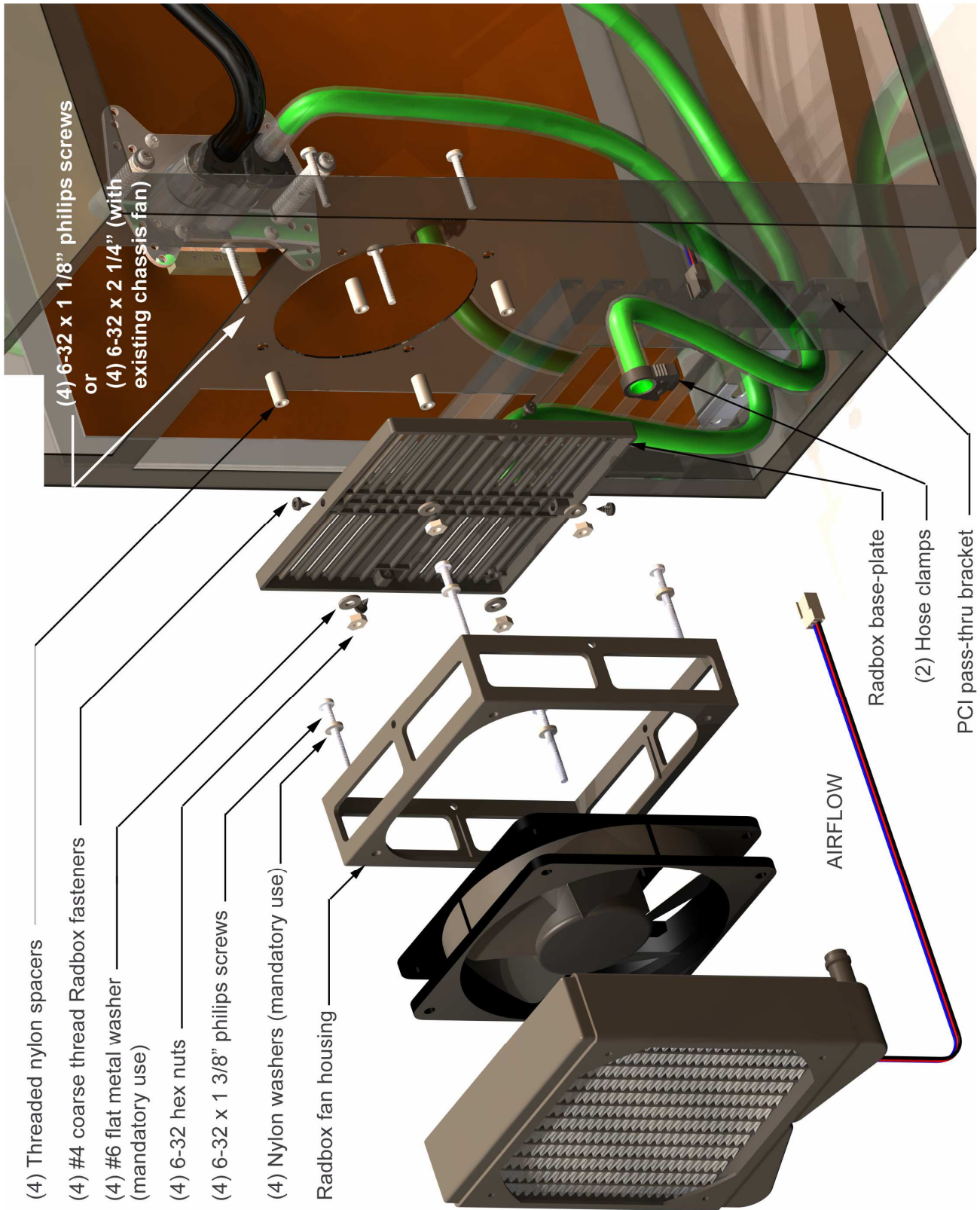



## 2. APOGEE GT WATER-BLOCK INSTALLATION

One or more Patents pending

This product is intended for expert users. Please consult with a qualified technician for installation. Improper installation may result in damage to your components. Swiftech™ assumes no liability whatsoever, expressed or implied, for the use of these products, nor their installation. The following instructions are subject to change without notice. Please visit our web site at [www.swiftnets.com](http://www.swiftnets.com) for updates.

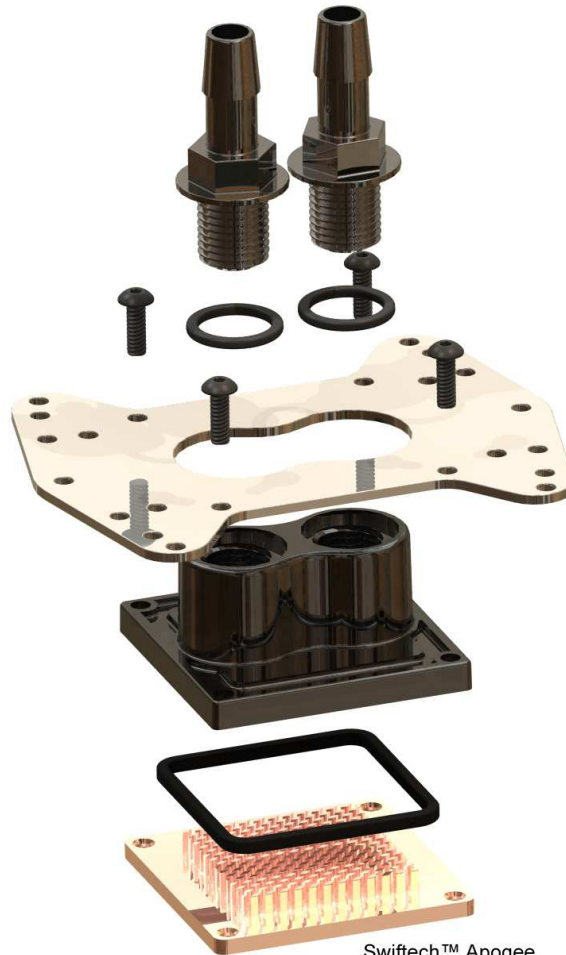

Swiftech™ Apogee  
One or more Patents Pending

**Figure 1 – Exploded View**

### Processor compatibility

#### Intel®

- ❑ Pentium® 4, D, Celeron
  - Socket 478 (option)
  - Socket 775
- ❑ Xeon™ (socket 603 and 604)
  - 400 & 533 MHz FSB
  - 800 MHz FSB (Nocona)

#### AMD®

- ❑ Athlon XP, MP, Duron, Sempron, socket 462 (option)
- ❑ Athlon 64, Sempron, Socket 754
- ❑ Opteron, socket 939, 940

## Packing List

COMPONENT ID	COMPONENT DESCRIPTION	QTY	USAGE
BHSC006C0-007SS	6-32 X 7/16 BUT HD CAP SS	4.00	WATER-BLOCK ASSEMBLY
O-RING 3/32	B1000-133 O-RING 3/32 X 1 13/1	1.00	WATER-BLOCK ASSEMBLY
APOGEE-H	APOGEE WATERBLOCK HOUSING	1.00	WATER-BLOCK ASSEMBLY
APOGEE-BRKT	APOGEE HOLD-DOWN PLATE	1.00	WATER-BLOCK ASSEMBLY
APOGEE-GT-BP	APOGEE GT BASE PLATE	1.00	WATER-BLOCK ASSEMBLY
BIG O-RING	BUNA-N 45MM ID	1.00	WATER-BLOCK ASSEMBLY
B1000-2.5X50	BUNA-N 70D BLACK O-RING	2.00	FITTINGS
PM4S-8BN	1/4" - 1/8 NPSM TO 1/2 ID	2.00	FITTINGS
22HC0672B	43/64" PREMIUM HOSE CLAMP	2.00	FITTINGS
SOCKET 775-BACKPLATE	SOCKET 775-BACKPLATE	1.00	INTEL® SOCKET 775
16FWRT004032	40-032 RETAINING WASHER	4.00	INTEL® SOCKET 775
13LTS2501400600	SPACERS	4.00	INTEL® SOCKET 775
LOCKWASHER6	LOCK WASHER #6	6.00	INTEL® SOCKET 775
M3X25-PAN-PHILIPPS	M3, 25 MM L, PHILIPPS	4.00	INTEL® SOCKET 775
WASHER-0148X0266X0040-91007A619	LOCK WASHER #6 X 0.040	4.00	AMD SOCKET 754/939/940,AM2 HARDWARE
90272A153-6-32X1.00-PHILIPS SCREW	6-32 X 1" PHILIPS SCREW	4.00	AMD SOCKET 754/939/940, AM2 HARDWARE
13RS040637	ROUND SPACER	4.00	AMD SOCKET 754/939/940,AM2 HARDWARE
APOGEE-AM2-BP	APOGEE AM2 BASE PLATE	1.00	AMD SOCKET AM2 HARDWARE
ST6977-0.250-34	3/16 HEX MALE FEMALE STANDOFF	4.00	NOCONA PACK
PPMS006C0016STZ1	6-32 X 1" PHIL PAN M/S STL	4.00	NOCONA PACK
16FW00432	WASHER	4.00	NOCONA PACK
13LTS2501400697	APOGEE NOCONA SPACER	4.00	NOCONA PACK
6-32 NUT	6-32 HEX M/S NUT STEEL	4.00	NOCONA PACK
ARCTIC CÉRAMIQUE	ARCTIC CÉRAMIQUE	1.00	THERMAL COMPOUND

## Common installation guidelines

- Removal of the motherboard is necessary to install the mounting posts in all cases, except for AMD® socket 754, 939, 940 and AM2.
- The water-block may be installed in any direction. Simply rotate the water-block in your hand prior to fasten it to the processor when you are filling up the circuit. This will purge it from any air bubbles.
- The inlet and outlet are interchangeable with respect to flow direction.
- Coolant: use of distilled water is mandatory. Swiftech's HydrX coolant is recommended as an antifungal, and corrosion inhibitor.

### 1. Step-by step

- Install the fittings with their o-rings into the water block. Tighten each fitting until the flange of the fitting mates with the ledge of the water-block, then lock it by adding ¼ to ½ turn.
- Remove the existing heat sink from your motherboard.
- Apply the provided Arctic Céramique thermal compound to the CPU following the comprehensive installation instructions provided here: [http://www.arcticsilver.com/ceramique\\_instructions.htm](http://www.arcticsilver.com/ceramique_instructions.htm)
- Install the Apogee water-block following the individual installation schematics for each type of CPU socket provided hereafter.
- Connect the tubing to the water-block hose-barbs. Use the provided hose-clamps to secure the tubing to the barbs.

### 2. Individual installation schematics

The Apogee GT ships pre-installed for socket 775. Both Nocona and AMD™(socket 754, 939, 940, AM2 and F) mounting hardware is included

## Intel® Pentium® 4 and Pentium® D Socket LGA 775

First, install the 775 backplate



Peel of the protective paper and position the backplate at the back of the motherboard. Firmly press it into the motherboard.

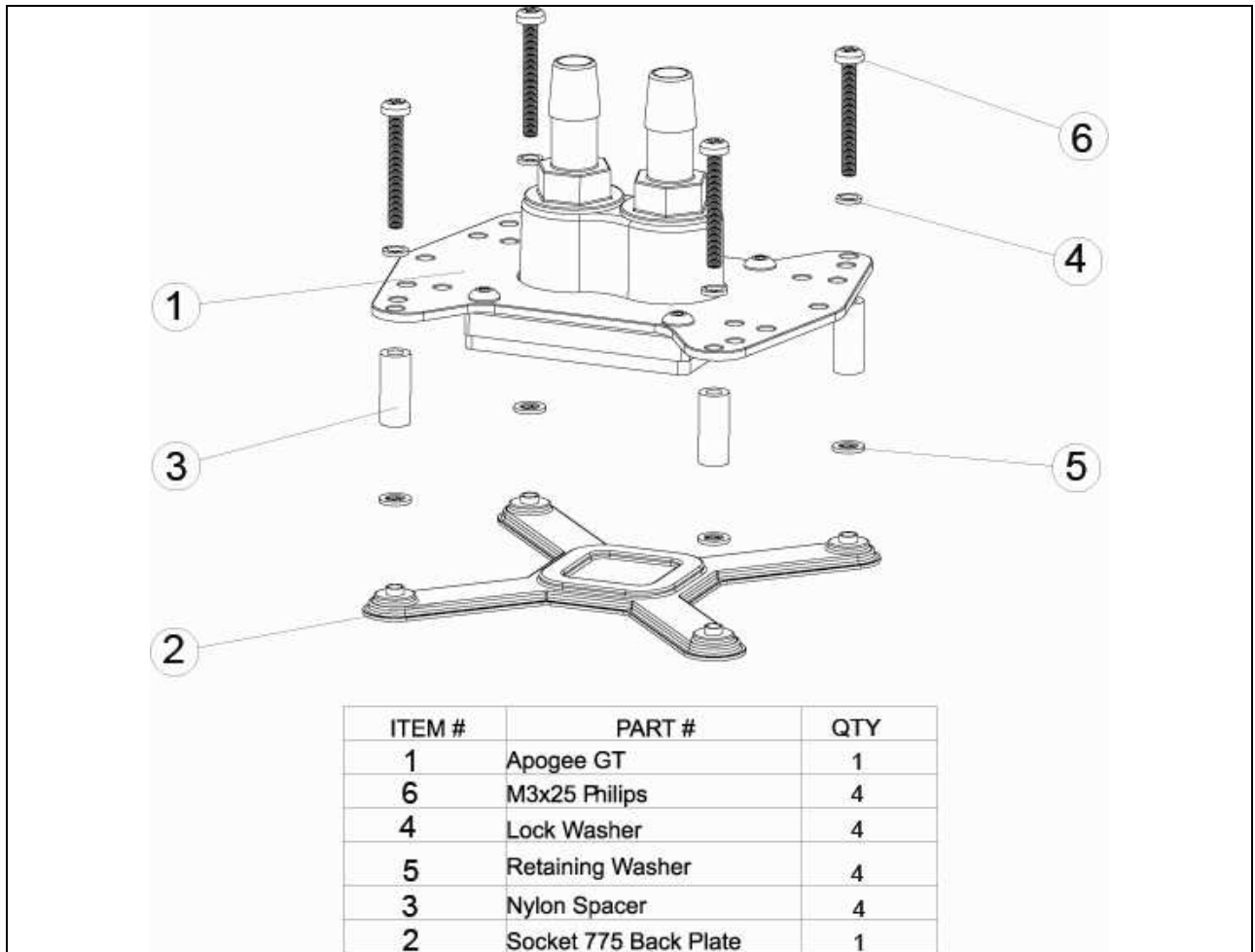

## Intel® Xeon™ Socket 604 “Nocona” 800 MHz FSB motherboards

**Use Intel Xeon “Nocona” separate hardware.**

ITEM NO.	PART NUMBER	DESCRIPTION	QTY.
1	Nocona board mockup	Motherboard	1
2	spring-backplate	retention spring (provided by motherboard vendors)	1
3	chassis		1
	3a STANDOFF-0.187		4
4	4-40 nylon retaining washer	4-40 nylon retaining washer	4
5	SPACER-13LTS2501400697	Apogee - Nocona nylon spacer	4
6	90272A153-6-32x1-philips	6-32 x 1" Philips zinc plated screw	4
7	apogee-assy		1
	APOGEE-H	Housing	1
	APOGEE-BP	Base Plate	1
	APOGEE-BRCKT	Universal hold-down plate	1
	7a O-RING-9557K473	1-4" NPSM barb fitting O-Ring	2
	7b 1-4-straightx3-8-barb	1/4" NPSM X 3/8" Barb fitting	2

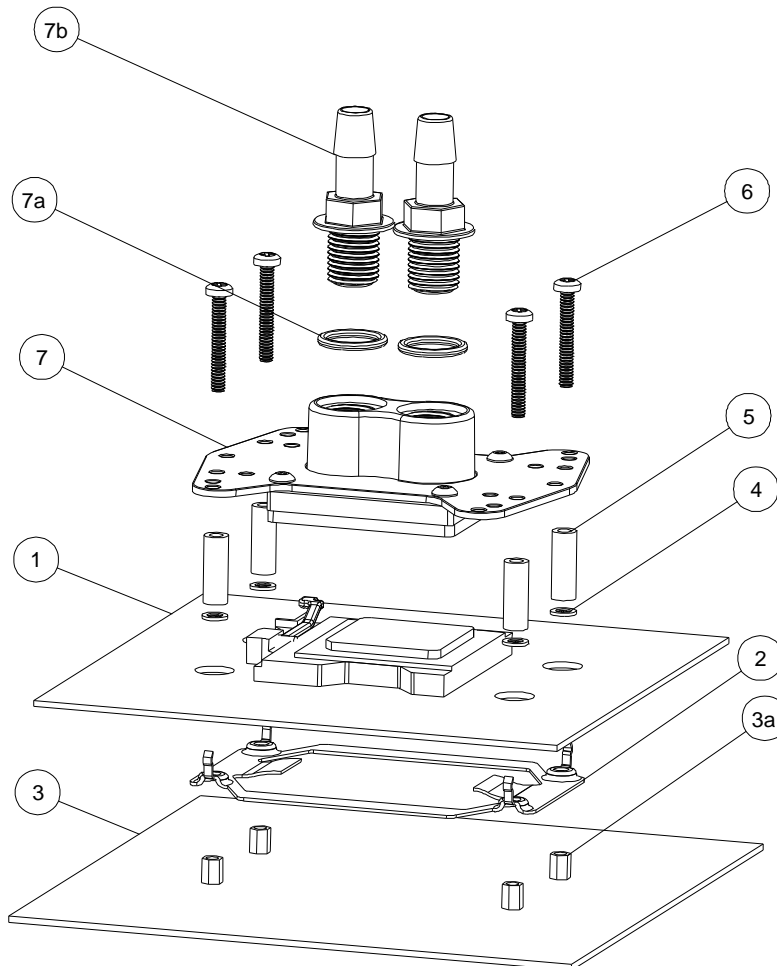

Note to dual processor users: since the Apex Ultra is provided with one Waterblock only, you will need to procure another Apogee Waterblock separately for your second. Please note that the “Nocona” hardware is not included with the Apogee Waterblock, and also needs to be procured separately under part number: AP-NC604 (\$3.00)

## AMD® 64, Sempron®, Opteron® Socket 754, 939, 940

**Use separate AMD 754/939/940 hardware pack**

ITEM NO.	PART NUMBER	DESCRIPTION	QTY
1	90272A153-6-32x1.00-philips	6-32 x 1" Philips screw	2
2	washer-0148x0266x0040-91007A619	Lock Washer #6 x 0.040	2
3	13RS040637	Nylon spacer for Apogee K8 assy	2
4	AJ00264	Motherboard Back plate (not provided)	1
5	1-4-NPSMx3-8-barb	1/4" NPSM X 3/8" Barb fitting	2
6	O-RING-9557K473	1-4" NPSM barb fitting O-Ring	2

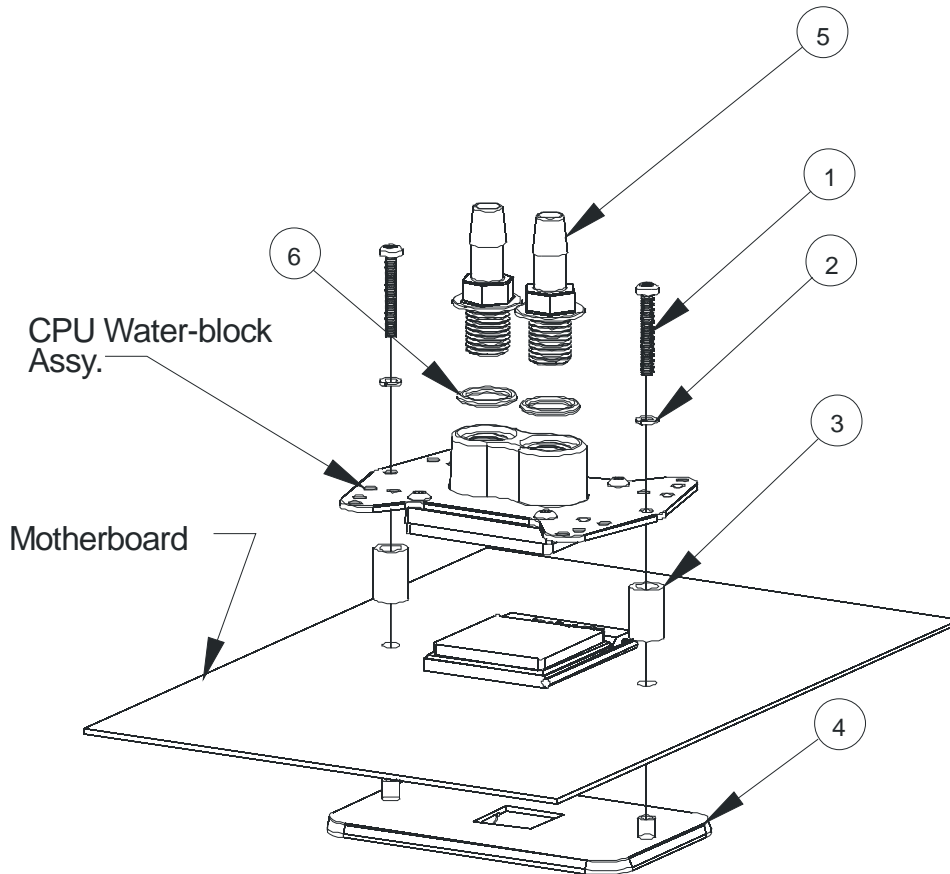

## AMD® 64, FX, X2, Sempron®, Socket AM2

Remove the pre-installed hold-down plate first, as described on the next page.

ITEM	PART NUMBER	DESCRIPTION	QTY
1	90272A153-6-32x1.00-philips	Philips screw	4
2	washer-0148x0266x0040-91007A619	Lock Washer #6 x 0.040	4
3	apogee-assy-AM2		1
4	13RS040637	Nylon spacer for Apogee K8 assy	4
5	SOCKET AM2		1

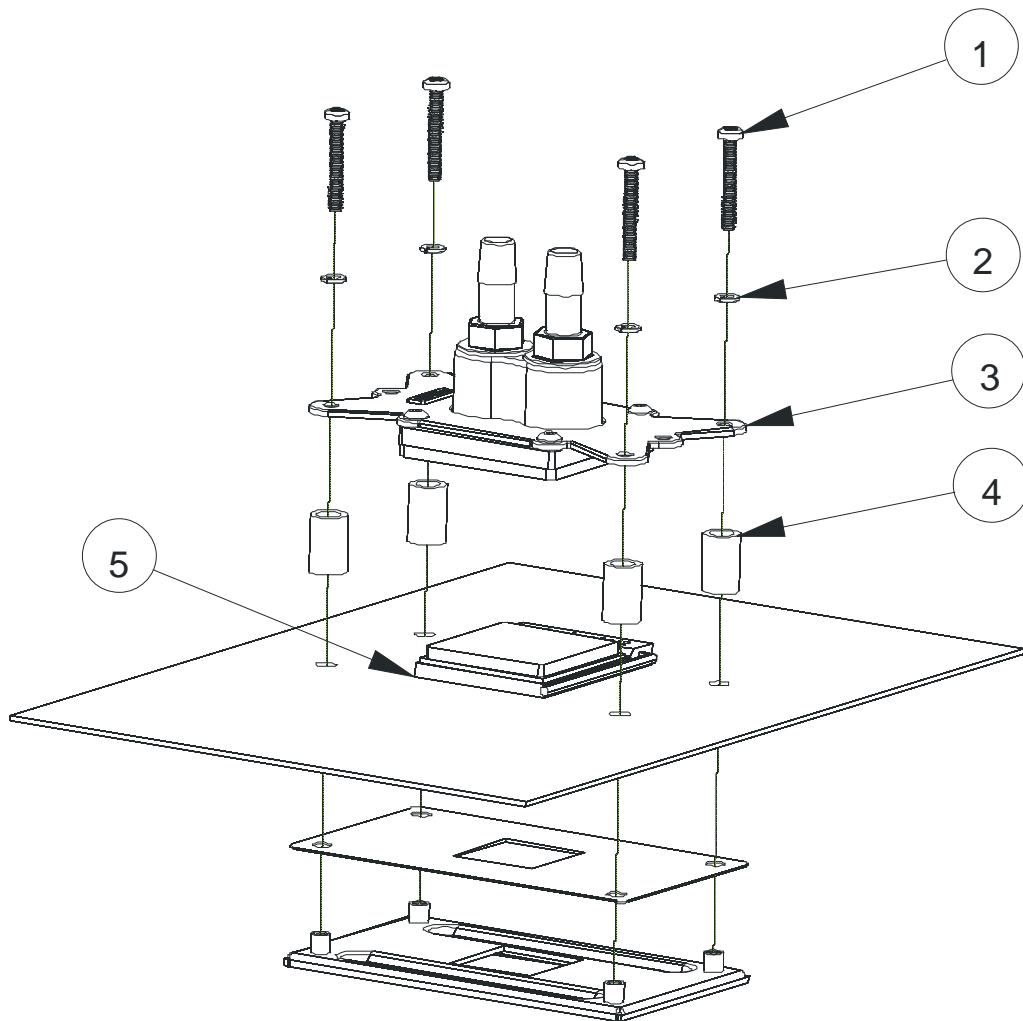

The Apogee GT water-block ships pre-installed with the multi-socket hold-down plate. In order to install your Apogee with AMD's AM2 socket, you will need to remove the existing hold-down plate and replace it with the AM2 model as follows:

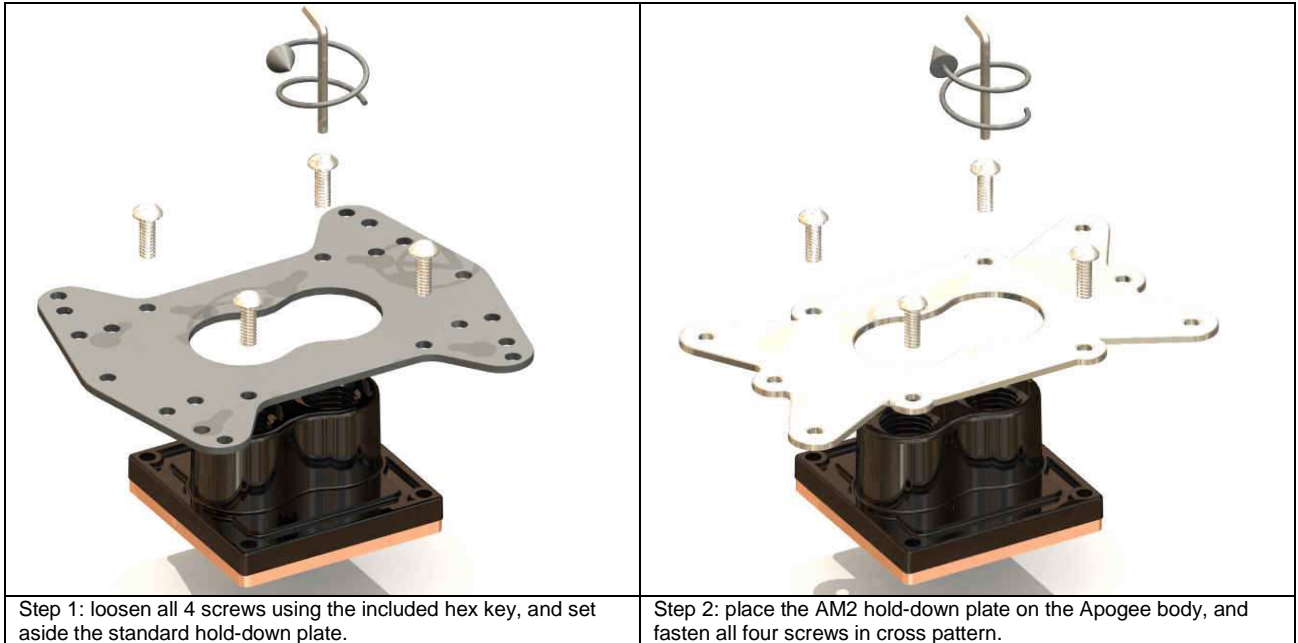

You can now use your Apogee GT with AM2 socket. Please read the common and step by step installation guidelines in page 2 to proceed with the installation of the product.

### 3. RE-INSTALLING THE MOTHERBOARD

Now that the APOGEE water-block is securely fastened to the motherboard, go-ahead and install the motherboard into the chassis, following the instructions provided in your motherboard installation guide.

### 4. PUMP INSTALLATION

#### □ General Use

The MCP655-B pump is a magnetically driven centrifugal pump featuring a 12 V DC motor. It requires no maintenance when used with de-mineralized water and the appropriate anti-fungal additives. We recommend using 5% Swiftech's HydrX™ as an additive. The pump is designed to be connected to your computer power supply using the standard Molex 4 pin connectors.

The MCP655-B pump is neither submersible, nor self-priming. The inlet needs to be continuously supplied with fluid for the pump to operate properly.

#### □ Physical installation

- Determine the best location for your pump by observing how the tubing will be routed to the rest of the circuit. Sharp bends in the tubing should always be avoided to prevent kinks, which will reduce or completely prevent flow of the cooling fluid.
- In general, we recommend installation of the pump at the bottom of the chassis.
- The base of the pump features a soft neoprene pad coated with **strong** adhesive material. Once the final location for the pump has been determined, simply peel-off the pad's protective paper, and press the pump against the chassis surface. The surface should be clean, and non greasy. Thru-bolts are also provided for permanent installation, and require drilling holes in the chassis.

#### □ Pump operating precautions:

**The MCP655-B pump should never be run dry, even for a quick test.** You should always prime the pump with fluid before you start operating it (see warranty note \*).

**Use of coloring die or fluorescent additives** containing particulate fillers will cause excessive wear to the pump's impeller bearing (see warranty note \*\*).

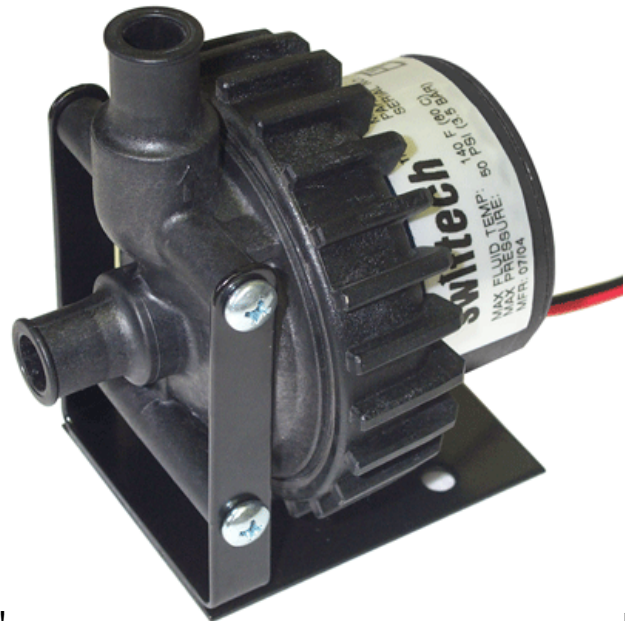

Error!

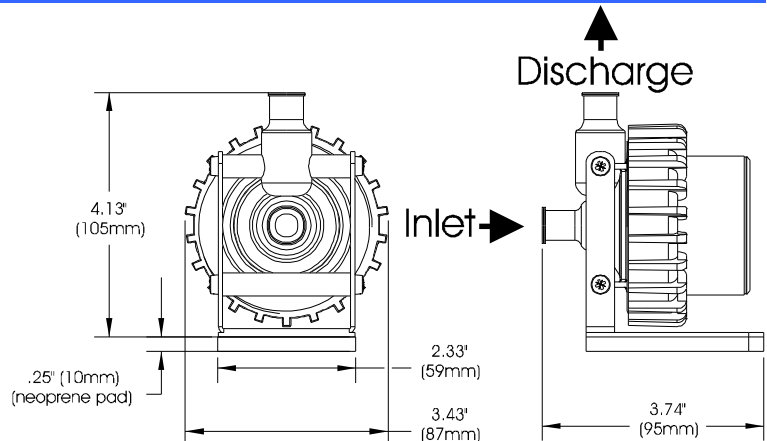

Note 1: Always make sure to directly connect the RESERVOIR DISCHARGE to the PUMP INLET.

Note 2: Please read important preamble in paragraph 5 below "Preparing the Tubing" prior to installing the tubing to your pump.



**Permanent installation to the chassis, and exploded view**

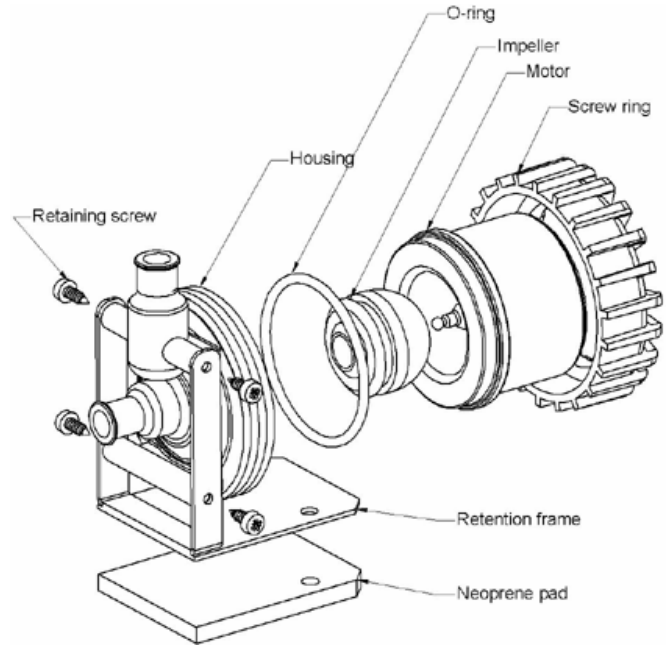
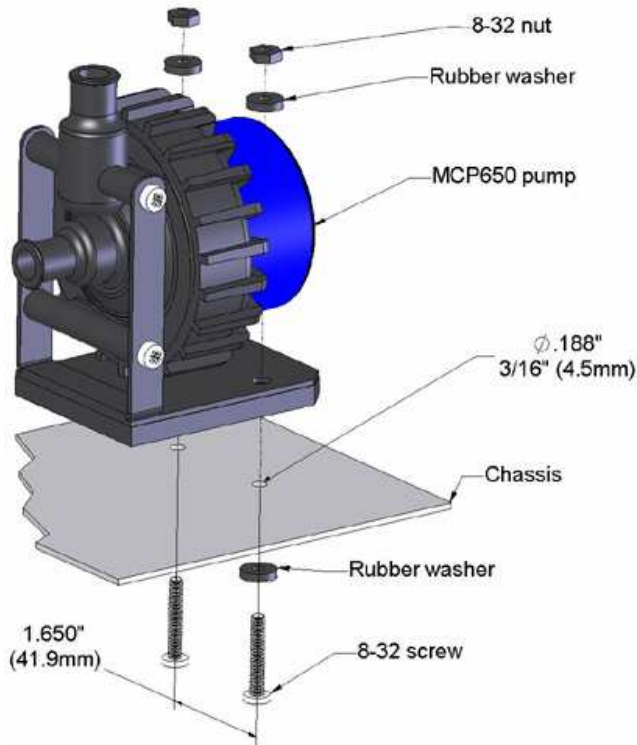

**Specifications:**

Nominal voltage / Connector	12 V DC / Molex 4 pin	Maximum pressure	50 PSI (3.5 BAR)
Operating voltage range	8 to 24 VDC	Maximum head	10 ft (3.1 m)
Nominal current (@ 12 V)	2 amps	Maximum discharge	~ 317 GPH (1200 LPH)
Nominal power (@ 12 V)	24 W	Temperature range	32 F° to 140F° (0 °C to 60 °C)
Motor type	Brushless, microprocessor controlled	Weight	1.4 LB (650 gr.)
Impeller Housing material	Noryl®	Connection size	½" barbs

## 5. PREPARING THE TUBING

Preamble:

Your kit comes with 7/16" ID (5/8" OD) tubing. This type of tubing was specifically selected following suggestions made by our enthusiast users because it offers very low flow restriction, similar to that of true 1/2" ID tubing, without the bulk of true 1/2" (which is 3/4" OD and therefore hard to work with). This tubing will fit easily onto standard 1/2" barbs EXCEPT for the MCP655 pump. In effect, the design of the hose barbs on this pump makes it quite difficult to install this slightly smaller tubing. Two things can be done to ease this process:

- Rub the pump barbs with liquid soap to make them slippery
- Soften-up the extremity of the tubes by dipping them in a glass of boiling water for about 20 to 30 seconds (boil some water in a microwave oven, then dip the extremity of the tube).

Then work the tube around the pump hose barbs by pushing it firmly. Be patient, it is not easy but it does work.

Smartcoils and tubing installation

Now that your radiator, water-block and pump are in place, it is time to cut segments of tubing and connect the devices together.

Your kit comes with a 40" length of Smartcoils which, when extended is a sufficient length to cover 6 feet of tubing. Use of these coils is recommended whenever there is a sharp bending radius in order to prevent kinking and flattening of the tube over time.

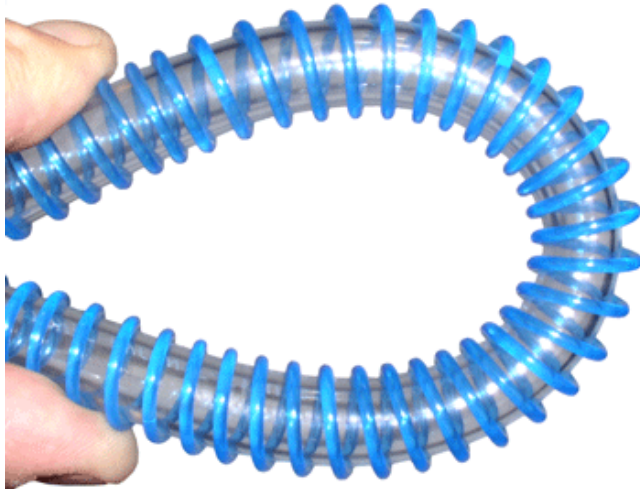

*Example of wrapping for a tight bend. (shown with the blue version for picture clarity – The kit actually comes with clear coils).*

*Wrap the Smartcoils around the tubing*

Gather the Smartcoils towards the center of the tubing, and then pull on the ends of the tubing. This will allow the coils to expand to their natural pitch.

Another technique to evenly spread the coils along the tubing consists in pushing one of the extremities of the coil clockwise. This will loosen the coils from around the tube, and allow you to spread them easily.

Tight radii sections require that coils be close to each other (1/8" spacing coil to coil). In straight sections, coils can be spaced up to 1/4" or more, coil-to-coil.

□ Then, with one end of a tube connected to a startup component such as the water-block for example, roughly estimate the length that you will need to the next component, and cut the tube and coil squarely with a pair of scissors. Work your way through the entire circuit in the same fashion, until you are satisfied with the tube routing.

□ Secure all the connections of tube to hose barbs with the provided hose-clamps:



## 6. MCRES-MICRO RESERVOIR INSTALLATION

ITEM NO.	PART NUMBER	DESCRIPTION	QTY.
1	MCRES-MICRO	Reservoir	1
2	1-4" NPSM x 3-8" and 1-2" barb	Barb fitting	2 pairs each
3	O-RING-9557K473	Barb fitting O-Ring	2
4	pg7-o-ring	Fill-cap o-ring	1
5	pg7-plug	Pg7 Fill-cap	1
6	MOUNTING HARDWARE		3
6a	90272A152-6-32x0500philips	6-32 x 7/8" (22mm) Philips screw	1
6b	90760A007	6-32 Nut	1
6c	washer-91007A614	Lock Washer	1
6d	WASHER-RUBBER-437X150X092	Rubber Washer	1
7	panel		1

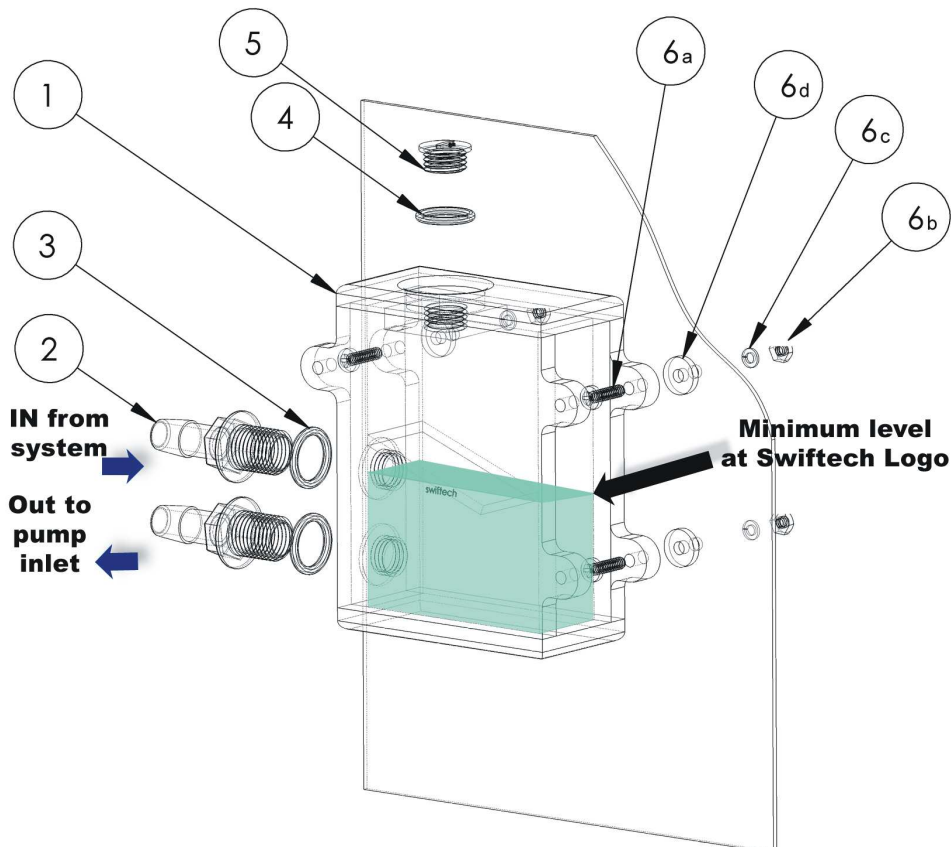

Schema 1

### □ Installation

- The MCRES-MICRO can be installed in any suitable location meeting its form factor requirements. For filling and bleeding purposes, it is preferable to hold or to install the MCRES-MICRO at the highest point of the liquid cooling loop. However, once filled and hermetically closed, the reservoir can be installed practically anywhere as long as it is kept upright as shown in figure 1. Also, to facilitate the filling and bleeding operations, you might want to wait until the circuit has been filled-up before you fasten the reservoir permanently to the chassis.

- Fastening the device to the case: two mounting methods can be used
  - **Permanent mount** with the provided mounting hardware as shown in figure 1. Three holes will need to be drilled for a permanent mount. Simply use the reservoir as a template to mark the hole locations, and use a 0.150" (4mm) drill bit to drill the holes. Make sure to clean up any metal shavings from the case once you are done.
  - **Easy mount**, with the provided Velcro strips. This is a fairly secure mount, as we use extra strong Velcro. However, if your computer is to travel often (LAN parties for example), a permanent mount remains more suited for a more reliable fastening of the device.
- **The only critical precaution to take when installing the reservoir is to make sure that the discharge line is directly connected to the inlet of the pump.** In other words, the pump (inlet) should be the first device connected to the reservoir discharge. Using a different routing will make the filling and bleeding of the circuit difficult, and may prevent the pump to prime properly.
- Once you have found a suitable location for the reservoir, go ahead and connect the tubing to the reservoir fittings, then secure them with the provided hose clamps.
- 

#### □ Preparing the coolant

- Your kit comes with a 2 Oz (60ml) bottle of Swiftech's specially formulated HydrX™ concentrated coolant. The product should be mixed with distilled water only. Simply empty the concentrated coolant into a 33 fl oz (1 liter) plastic bottle, and complete filling with distilled water. Your coolant is now ready. Note: a 5% mix might still allow some algae formation over prolonged usage if your system is continuously exposed to daylight (such as a clear acrylic case for example). Under such circumstances, we would suggest using a 10% mix.
- **Use of alcohols (Alcohol Allyl, Amyl, Benzyl, Ethyl (Ethanol), Isopropyl, Methyl (Methanol), n-Butyl) or antifreeze products containing the listed alcohols is prohibited as it will result in deterioration of the reservoir over-time, and will void your warranty.** Resistance to Ethylene and Methylene glycol used in antifreeze products is excellent.
- **Minimum Operating Level** is situated at the Swiftech Logo (approximately ½" of the reservoir). The reservoir should not be operated below this level, which could result in degradation of the system cooling.

## MCRes Micro Bracketry installation and examples

ITEM NO.	PART NUMBER	DESCRIPTION	QTY
1	BCKT1	"L" bracket	1
2	BCKT2	"U" bracket	2
3	90272A146-6-32x3-8-philips	6-32 x 3/8" Philips screw	3
4	91772A158-6-32X1.75	6-32 x 1 3/4" Philips screw	2
5	90760A007	6-32 Nut w/leath washer	3
6	FW150X437X092	Rubber Washer 437X150X092	2
7	93286A041-WASHER	zinc plated washer	5

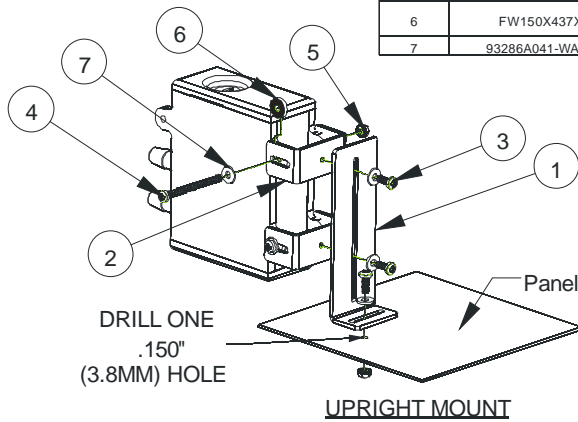

Note 1: rubber washer 6 should be inserted between either side of the reservoir ear and the U bracket 2.

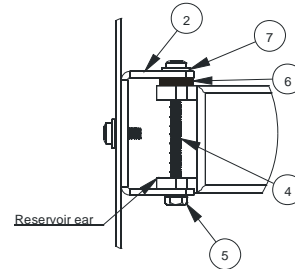

### HANGING MOUNT

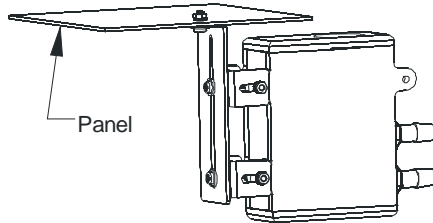

### BACK-PANEL MOUNT

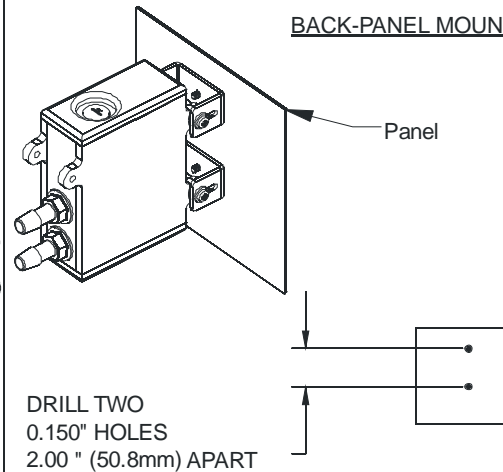

Note 2: the 6-32 x 1 3/4" screw #4 & nut # 5 assembly is designed to protrude as little as possible in order to reduce overall clearance necessary for the Micro Res assembly. It is thus necessary to slightly push the nut in order to engage it on the screw thread.

### ❑ Re-installing your power-supply

- Prior to fill-up the circuit, you will need to re-install your power-supply in order to start-up the pump during the fill procedure. You must be able to start the PSU without it being connected to the motherboard. While the Internet contains numerous references on how to use a paper-clip to short-out pin 13 and 14 of the 20 pin ATX connector as shown below, we nonetheless recommend instead using a power-supply tester. A wide variety of these common devices are available on the Internet (**Google** key word: "PSU tester"), and among Swiftech resellers ([www.frozenscpu.com](http://www.frozenscpu.com), [www.Directron.com](http://www.Directron.com), [www.newegg.com](http://www.newegg.com), etc.).

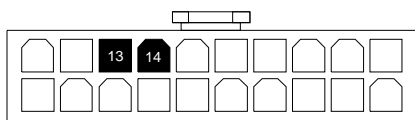

❑ **Filling-up the circuit**

- Simply pour the coolant that you prepared into the reservoir – **carefully to avoid spills**, allowing the circuit to fill-up by simple gravity. Note: for the gravity to take effect the reservoir should be placed or held at the highest point of the cooling circuit. Once the reservoir is full, seal the fill port back with its cap in order to avoid any spills, and start-up the pump. The reservoir will quickly (within 1 second) empty itself. Immediately turn off the pump, top-off the fluid to the maximum level, and restart the pump. You need to repeat this operation 2 to 3 times, until the circuit is finally full of coolant. Then, allow the system to run 10 minutes uninterrupted to clear all the micro-bubbles and foam, and finally top-off the level one last time. Your liquid cooling circuit is now ready, and you may permanently install the reservoir.
- **Allow the system to run for (3) hours and frequently inspect all your connections for possible leaks before you reconnect and re-install all your components (motherboard, hard drives, etc.)**

---

**CONGRATULATIONS, YOUR INSTALLATION IS NOW COMPLETE!**

---



**Example of installation (including the MCW55 VGA cooler)**

## 7. TROUBLESHOOTING

- ❖ **Air keeps circulating into the circuit, long after the pump has primed:**
  - There is a significant pocket of air trapped into the circuit. In most cases this will be due to the fact that the radiator and or the water-block where installed upside down. Temporarily dismount the device and re-orient right side-up until all the air has escaped back into the circuit.
  - The fluid level is too low: top-off the reservoir to the appropriate level.
  - One of the components connections is loose, or improperly tightened: Inspect each connection for traces of moisture, and tighten all worm-drive clamps, and various connections in the circuit.
- ❖ **The pump does not prime.**

It is likely that the circuit is not installed correctly. Please check that the reservoir discharge is duly connected to the pump inlet. Reminder: do not let the pump run dry.
- ❖ **The Coolant is filled with debris of some sort:**

Despite our best efforts, such as lengthy ultrasonic cleaning of the radiator, and careful inspection and cleaning of all the parts we manufacture, it is always possible that debris or some sort may be contaminating your circuit. When this happens it will significantly affect the performance of the APOGEE water-block, which mini-jets can be easily obstructed due to their small size. The circuit should then be completely flushed (see draining procedure below), and the APOGEE water-block should be disassembled for inspection and cleaning.

## 8. DRAINING THE SYSTEM

- Open up the fill-cap from the MCRES-Micro
- Then, you will need to disconnect a line from one of the lowermost components. Typically, this would be the pump. You need to procure a bucket large enough to receive approximately 1 liter of fluid, and place the bucket underneath the connection that you intend to "break". Disconnect the line, and place both ends into the bucket, until all the liquid is drained from the system.

## 9. PERIODIC MAINTENANCE

- Every 6 months: dust off the radiator fins and fan. You can use a can of compressed air for example, available in most electronic supply stores. If you live in a very dusty area, you should perform this task at closer intervals. It is essential to maintain the optimum performance of your cooling system.
- Inspect the liquid level inside the reservoir, and refill if necessary (no refills are normally necessary for 18 months of continuous usage). Evaporation in this closed circuit is extremely limited, but still present due to some permeability in the vinyl lines.

## 10. OPTIONAL COMPONENTS

Liquid Cool your high-end SLI VGA with the [MCW55™](#)

To use this water-block with the 7/16" tubing shipped with the Apex kit, please use the [1/2" Tube ID Hose barb adapters](#) - Part # PI251616S "Fitting: 1/2 in. Stem to 1/2 in. barb"



Notes: flow-wise, these fittings are equivalent to standard brass 1/2" barbs. The red clip is also provided to prevent any accidental removal of the fitting during operations.

Cool the graphics memory with our [MC14](#) Ramsinks



Add a second [Apogee](#) water block for multiprocessor applications, such as dual AMD®, dual Xeon™, or dual Opteron™

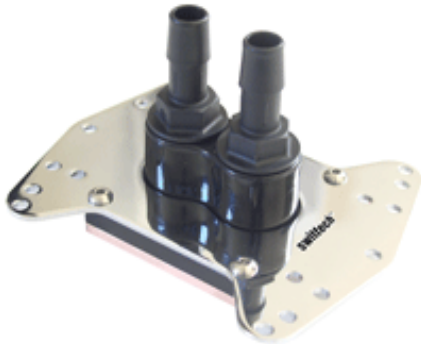

For Dual Xeon “Nocona” users do not forget to add the optional Nocona hardware (part AP-NC604) when you purchase your second Apogee water-block. In effect, while this hardware is included in this kit, it is not included when the Apogee water-block is sold separately.

Cool the Chipset with the [MCW30](#) chipset cooler.

