

MCX462-U™ Heat Sink

Packing list

| Parts | Qty | Parts | Qty |
|-------------------------------|-----|-------------------------|-----|
| Heat Sink | 1 | Springs | 4 |
| Fan | 1 | .230x.096 Nylon spacers | 8 |
| Fan guard | 1 | .220x.046 Nylon spacers | 4 |
| 6-32 x 2" screws (for fan) | 4 | Nylon 6-32 Hex nuts | 4 |
| 6-32 x 1 1/2" screws (for HS) | 4 | Black fiber washers | 8 |
| Standoffs | 4 | Thermal grease | 1 |

AMD® Installation Guide

I. Preparing the motherboard

1. **You must uninstall** your MB prior to installing the MCX462-U™ heat sink.
2. **Install standoffs in MB**
Determine which standoff washers to use, depending on your MB mounting holes:
 - Large holes .230"(5.8mm) diameter : use .220x.046 Nylon spacers. The washers fit inside the MB hole.
 - Small **grounded** holes .150"(3.8mm) diameter: you can recognize grounding by a silver ring around the holes; no washers needed nor necessary.
 - Small holes, **NOT grounded** (bare circuit board): you **must** use black fiber washers, or damage to the MB may occur.

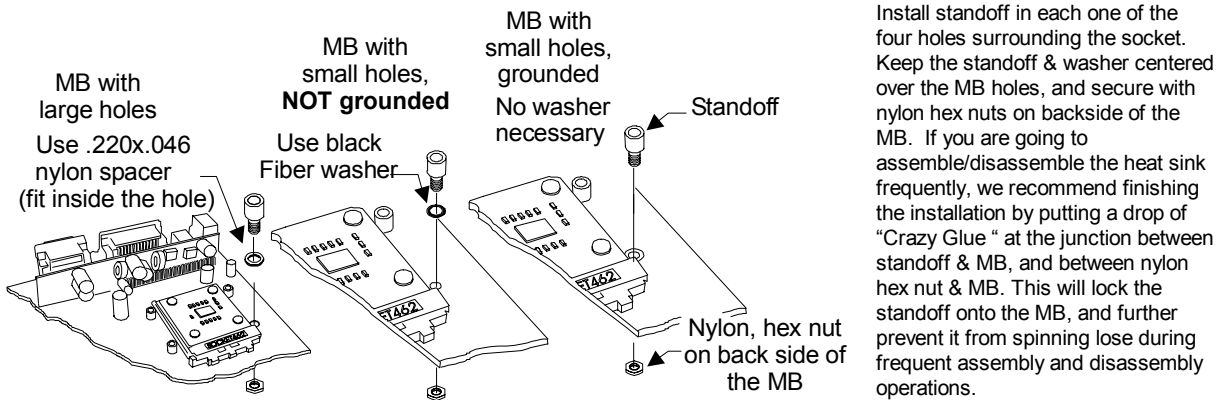

3. **Re-install the MB** inside the case.

II. Heat sink Installation

1. **The case should** be laying flat on a table.
2. **Insert the processor** into the socket, and lightly coat the processor core with high quality thermal compound. **Only a paper thin coat is necessary.** It should be applied using preferably a razor blade, or a credit card, held between thumb and index at a 45 degree angle. It is critical to ascertain that the entire core is covered with a uniform coat of thermal compound. Thermal performance will dramatically decrease if any portion of the core is not covered by thermal compound. We recommend Arctic Silver or similar high end compound for superior thermal conductivity.
3. **Place the bare MCX462-U™** heat sink over the CPU as shown in the picture to the right. The step side should be located over the socket's cam box. Keep the heat sink mounting holes lined up with the standoffs.

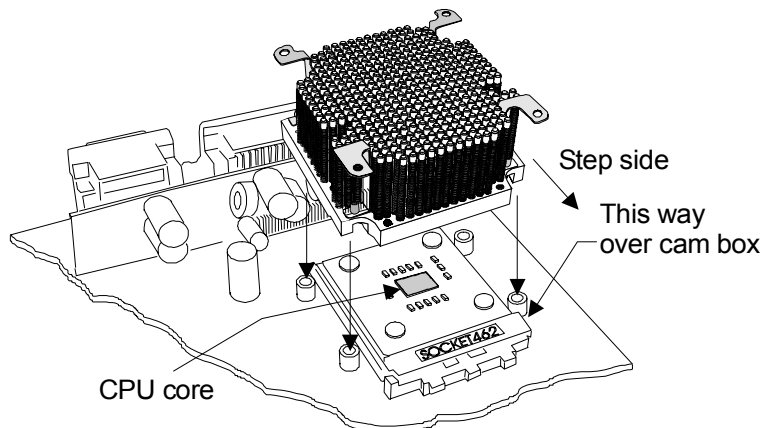

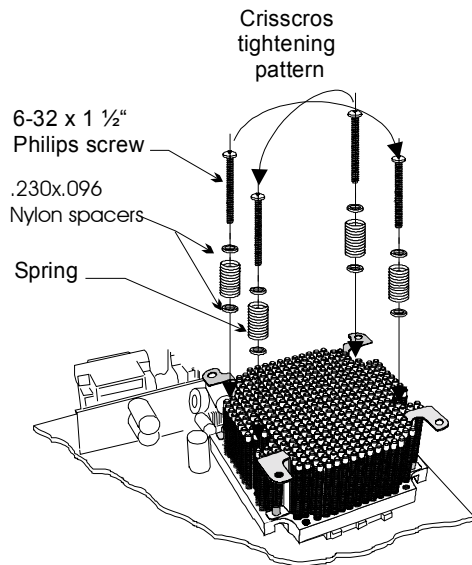

4. **Prepare 4 assemblies** composed of (1) 1 1/2" screw, (2) .230x.096 Nylon spacers, and (1) spring as shown in the picture to the left. Drop each assembly in the heat sink mounting holes. While gently pressing at the center of the heat sink, start tightening the screws gradually in a crisscross pattern until you feel that they reach the bottom of the standoff. A "finger-tight" lock is sufficient. Over tightening may result in stripping the nylon hex nut. Conversely, adjustments such as tightening the screws only partially are **strictly prohibited**. Such attempts will result in improper contact between the CPU core and the heat sink, and result in CPU overheating.

5. **Fan Installation:** Place the fan over the heat sink. The airflow should be blowing down (fan label facing down). Place the fan guard over the fan. Tighten the four 6-32 x 2" screws. The fan is equipped with two connectors: a four pin molex connector which must be connected to the power supply, and a 3 pin single wire connector which connects to the MB fan sensor header.
6. **Optional fan rheostat:** a rheostat model # RH070 is sold separately, and allows to adjust the fan speed. It connects between the fan power connector and the power supply connector. Please consult your distributor if you wish to purchase this item. Reducing the fan speed reduces fan noise up to 9 dBA. It also reduces thermal performance, and will affect overclocking performance accordingly. It is however perfectly appropriate for non overclocked processors.

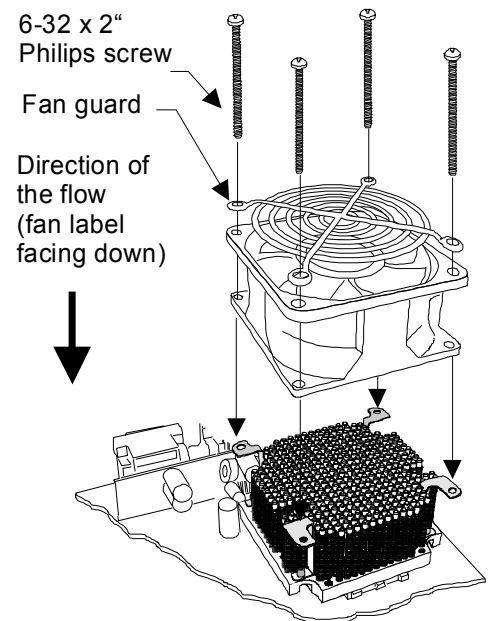

III. Final inspection

Now that the heat sink is installed, startup your computer, go into the BIOS and observe the CPU temperature. Under normal ambient temperature conditions, the processor temperature should never exceed 55° C (130 ° F). If it does, shut down the computer immediately, and review your entire installation. Troubleshooting help is available on our web site at www.swiftnets.com, or by calling customer support at 562-595-8009.

Uninstall note: CPU removal from some socket motherboards

Once in place, the standoffs may slightly interfere with CPU removal in some motherboards:

Depending on the manufacturers, sockets use either a plastic locking arm, or a metal locking arm. *Sockets using a plastic locking arm* require that the arm be slightly pried open at the center in order to release it from its retaining tab. This can easily be done by inserting a thin screwdriver in between the socket body and the arm's mid-section, and by slightly twisting the screwdriver in either direction, *while pulling on the arm*. This will slightly arch the mid-section of the arm, and release it from its locking tab.

DISCLAIMER: Swiftech assumes no liability whatsoever, expressed or implied, for the use of these products.

MCX462-U™ Heat Sink Intel® Installation Guide

I. Preparing the motherboard

4. You must uninstall your MB prior to installing the MCX462-U heat sink.
5. Install standoffs in MB.

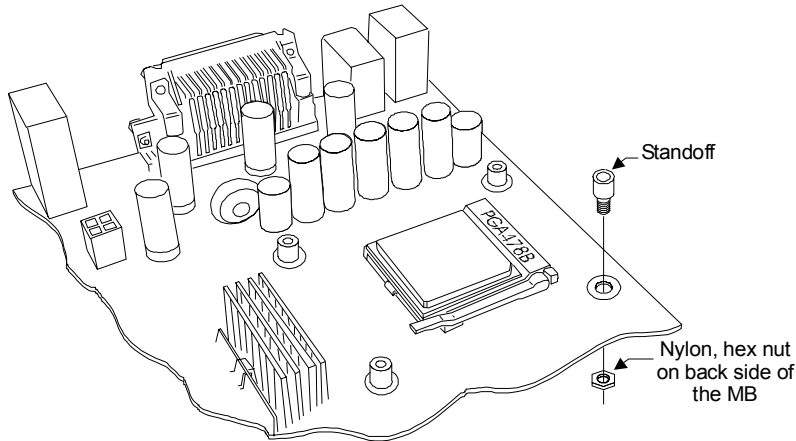

Do not install, or remove (if already installed) Intel® stock retention mechanism (black plastic frame). Install standoff in each one of the four holes surrounding the socket. Keep the standoff centered over the MB holes, and secure with nylon hex nuts on backside of the MB. If you are going to assemble/disassemble the heat sink frequently, we recommend finishing the installation by putting a drop of "Crazy Glue" at the junction between standoff & MB, and between nylon hex nut & MB. This will lock the standoff onto the MB, and further prevent it from spinning loose during frequent assembly and disassembly operations.

6. Re-install the MB inside the case.

II. Heat sink Installation

1. Install the two mounting brackets onto the heat sink, using the provided 4-40 x 1/4" socket screws:

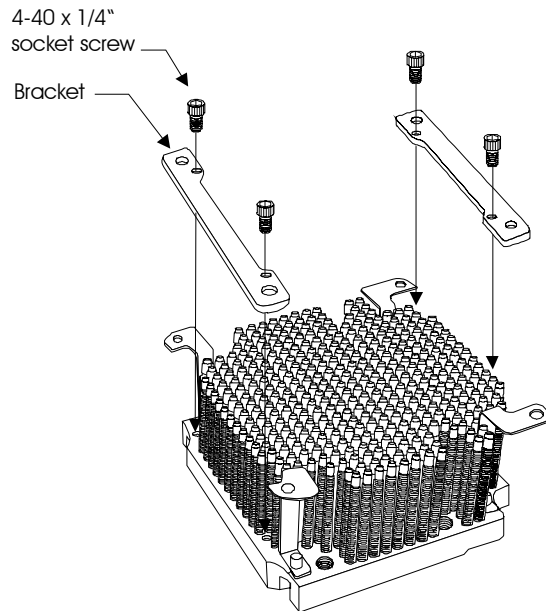

2. For the next step, the case should be laying flat on a table

3. Insert the processor into the socket, and lightly coat the processor core with high quality thermal compound. **Only a paper thin coat is necessary.** It should be applied using preferably a razor blade, or a credit card, held between thumb and index at a 45 degree angle. It is critical to ascertain that the entire core is covered with a uniform coat of thermal compound. Thermal performance will dramatically decrease if any portion of the core is not covered by thermal compound. We recommend Arctic Silver or similar high end compound for superior thermal conductivity.
4. Place the bare MCX462-U heat sink over the CPU as shown in the picture below. The step side should be located over the socket's cam box. Keep the heat sink mounting holes lined up with the standoffs.

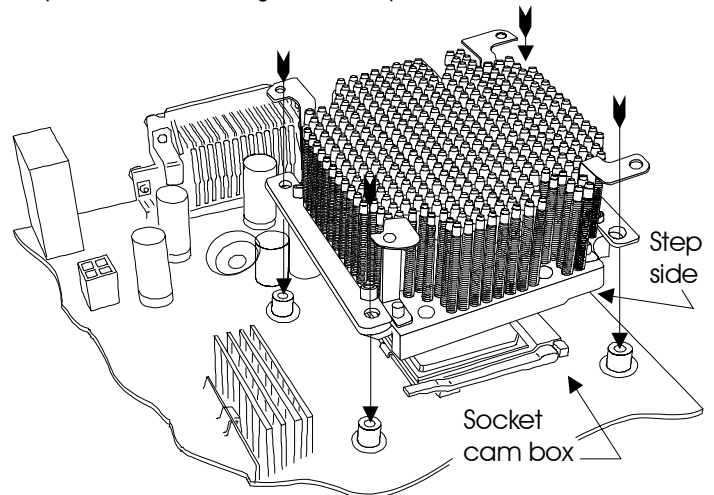

5. **Prepare 4 assemblies** composed of a 1 1/2" screw, 2 nylon flat washers, and 1 spring as shown in the picture to the right. Drop each assembly in the bracket mounting holes. While gently pressing at the center of the heat sink, start tightening the screws gradually in a crisscross pattern until you feel that they reach the bottom of the standoff. A "finger-tight" lock is sufficient. Over tightening may result in stripping the nylon hex nut. Conversely, adjustments such as tightening the screws only partially are **strictly prohibited**. Such attempts will result in improper contact between the CPU core and the heat sink, and result in CPU overheating.

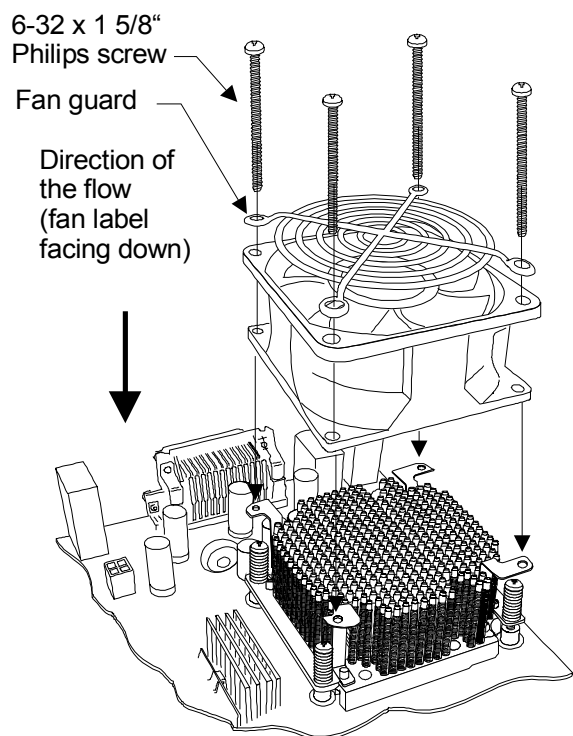
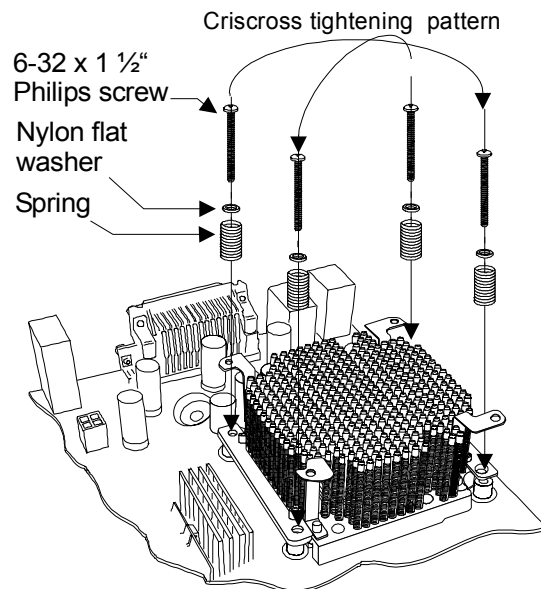

6. **Fan Installation:** Place the fan over the heat sink. The airflow should be blowing down (fan label facing down). Place the fan guard over the fan. Tighten the four 6-32 x 1 5/8" screws. The fan is equipped with two connectors: a four pin molex connector which must be connected to the power supply, and a 3 pin single wire connector which connects to the MB fan sensor header.
7. **Optional fan rheostat:** a rheostat model # RH070 is sold separately, and allows to adjust the fan speed. It connects between the fan power connector and the power supply connector. Please consult your distributor if you wish to purchase this item. Reducing the fan speed reduces fan noise up to 9 dBA. It also reduces thermal performance, and will affect overclocking performance accordingly. It is however perfectly appropriate for non overclocked processors.

III. Final inspection

Now that the heat sink is installed, startup your computer, go into the BIOS and observe the CPU temperature. Under normal ambient temperature conditions, the processor temperature should never exceed 55° C (130 ° F). If it does, shut down the computer immediately, and review your entire installation. Troubleshooting help is available on our web site at www.swiftnets.com, or by calling customer support at 562-595-8009.

DISCLAIMER: Swiftech assumes no liability whatsoever, expressed or implied, for the use of these products.